

Installation for Chevrolet Corvette C7 Stingray PNs: 60548 and 60558



These instructions have been written to help you with the installation of your Borla Performance Exhaust System. Please read this document completely before beginning the installation of your system.

Please compare the parts in the box with the bill of materials provided to assure that you have all the parts necessary for this installation.

To ensure this part number fits your specific model year, please visit our website for the latest model year listings at www.BORLA.com.

Thank you for purchasing a Borla Performance Exhaust System component.

Borla Performance component PNs 60548 and 60558 are designed for the Chevrolet C7 Corvette Stingray Coupe or Convertible equipped with a 6.2L V8 normally-aspirated engine and RWD automatic or manual transmission.

Borla Performance Industries recommends that an exhaust shop or professional after market parts installer, who has all the necessary equipment, tools and experienced personnel needed for proper installation, should perform the installation of this system. However, if you decide to perform the installation, we recommend someone should help you. Ensure the installer uses all under car safety precautions including eye protection.

Please take time to read and understand the following...

By installing your Borla Performance Exhaust System, you indicate that you have read this document and you agree with the terms stated below.

It is the responsibility of the purchaser to follow all installation instruction guidelines and safety procedures supplied with your Borla Performance Exhaust System.

Borla Performance Industries assumes no responsibility for damages occurring from misuse, abuse, improper installation, improper operation, lack of responsible care, or all previously stated reasons resulting from incompatibility with other manufacturer's products and/or systems.

Included with your Borla Performance Exhaust System is a warranty card. Please read it carefully before you begin any work on your vehicle. If you should have any questions regarding our warranty policy, installation, or any other matter pertaining to your new Borla Performance Exhaust System, please give us a call at the number provided on the warranty card.

Minimum Required Tool List:

TOOLS:

1. 3/8" Drive Ratchet
2. 3/8" Drive Extension 9"
3. 18mm Socket
4. 3/8" Universal Swivel
5. 15mm Socket
6. 13mm Socket
7. 10mm Socket

8. 8mm Socket
9. 7mm Socket
10. Pry Bar
11. Reciprocating Saw with metal cutting blade

SHOP SUPPLIES:

1. Spray lubricant

Borla Performance - Bill of Materials

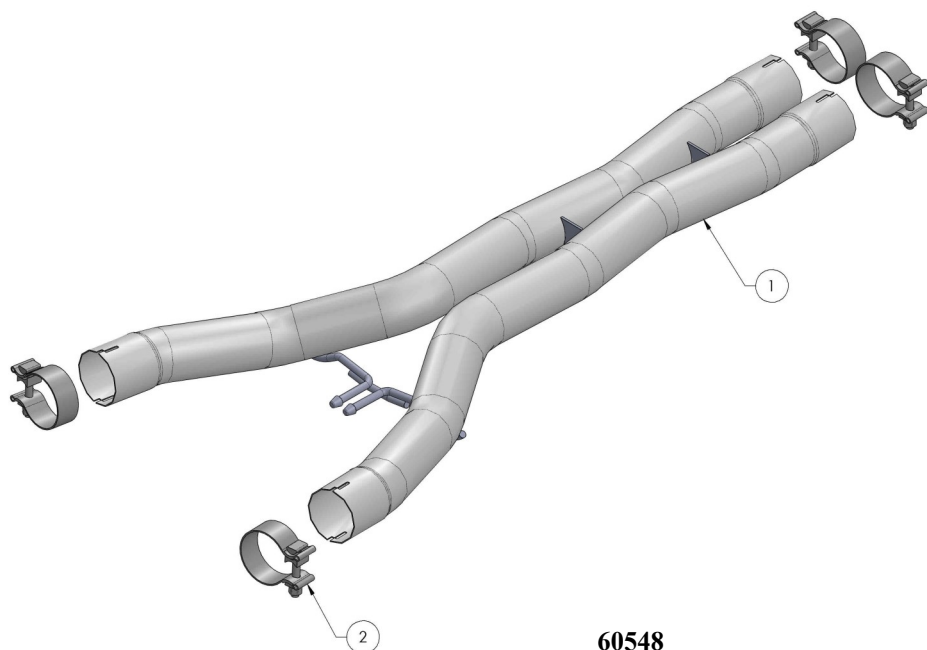

60548

ITEM NO.	PART NUMBER	DESCRIPTION	QTY.
1	55158	X-PIPE ASSEMBLY	1
2	90116	S/S ACCUSEAL CLAMP: Ø2.75	4

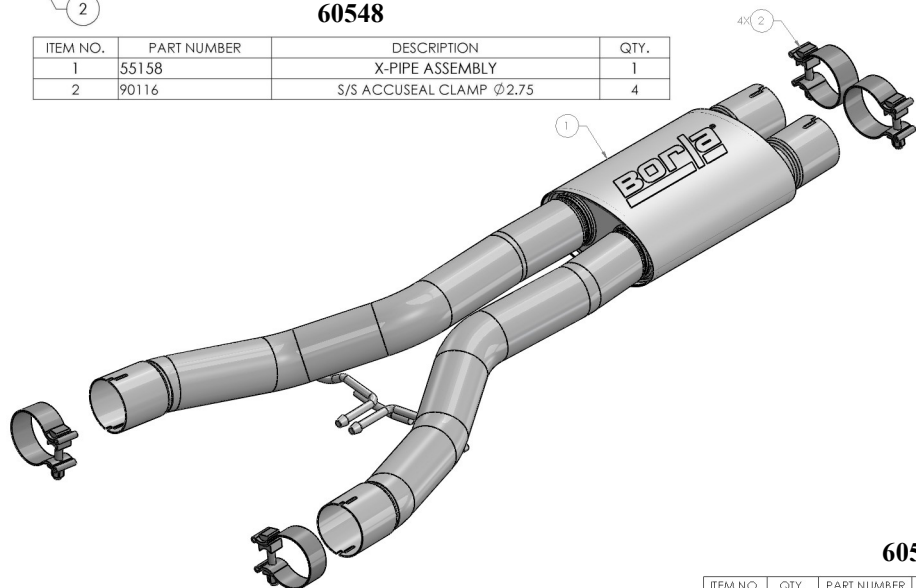

60558

ITEM NO.	QTY.	PART NUMBER	DESCRIPTION
1	1	55563	MUFFLER ASSEMBLY
2	4	90116	S/S ACCUSEAL CLAMP: Ø2.75

Caution!!! Never work on a hot exhaust system. Serious injury in the form of burns can result
If the vehicle has been in use and the exhaust system is hot, allow vehicle to cool for at least 1 hour. Always wear eye protection when working under any vehicle.

Note: It is our recommendation that you use a hoist or hydraulic lift to facilitate the installation of your new Borla Performance Exhaust System.

Taking all under car safety precautions, lift the vehicle using a hoist or hydraulic lift. Once this has been done, you may begin the removal of your old exhaust system from your vehicle.

Note: Before removing the original exhaust system from your vehicle, please compare the parts you have received with the bill of materials provided on the previous page to assure that you have all the parts necessary for the installation of your new Borla Performance Exhaust System.

Note: With a used vehicle, we suggest a penetrating spray lubricant to be applied liberally to all exhaust fasteners and allowing a significant period of time for the chemical to lubricate the threads before attempting to disassemble.

Original Exhaust System Removal

1. Loosen and remove bolts holding Tunnel Stiffening Brace using 13mm and 15mm sockets. *Note (2) keyhole-slots in the middle of the brace. Loosen (do not remove these bolts) and carefully slide brace rearwards and remove. Keep for reinstallation later (Fig. 1).*
2. Loosen and remove flange bolts at front of mid-pipe. Keep hardware for reinstallation late (Fig. 2).
3. Loosen and remove 13mm bolts at rear of mid-pipe. Loosen (2) 15mm clamp nuts at rear of mid-pipe (do not remove clamps) (Fig. 3).
4. Carefully remove factory x-pipe from vehicle (Fig. 4).

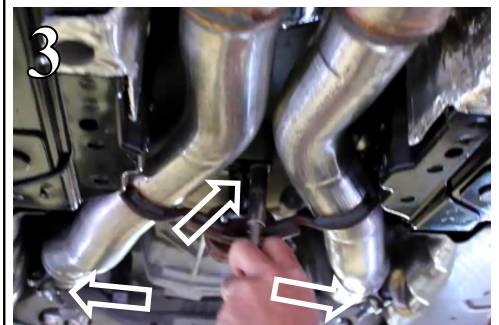
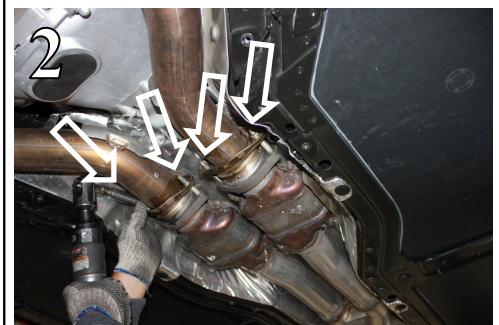
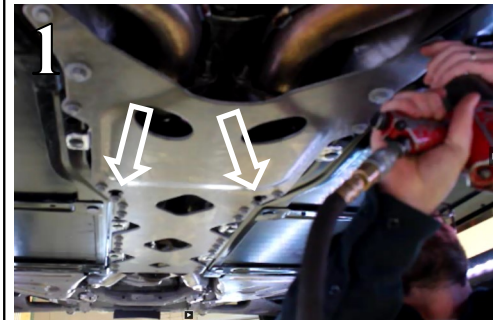

Caution!!! Never work on a hot exhaust system. Serious injury in the form of burns can result
If the vehicle has been in use and the exhaust system is hot, allow vehicle to cool for at least 1 hour. Always wear eye protection when working under any vehicle.

Note: It is our recommendation that you use a hoist or hydraulic lift to facilitate the installation of your new Borla Performance Exhaust System.

Taking all under car safety precautions, lift the vehicle using a hoist or hydraulic lift. Once this has been done, you may begin the removal of your old exhaust system from your vehicle.

Note: Before removing the original exhaust system from your vehicle, please compare the parts you have received with the bill of materials provided on the previous page to assure that you have all the parts necessary for the installation of your new Borla Performance Exhaust System.

Note: With a used vehicle, we suggest a penetrating spray lubricant to be applied liberally to all exhaust fasteners and allowing a significant period of time for the chemical to lubricate the threads before attempting to disassemble.

Borla Performance Installation PN - 60548 + 60558 (Cut & Clamp Factory Catalytic Converters)

1. Orient components on shop floor according to Borla bill of materials drawings on page 2.
2. Factory x-pipe and Borla 60548 (60558 not shown) (Fig. 5).
3. Place factory x-pipe on flat surface. Measure and mark a cutting line 4" from x-pipe weld on left and right pipe (Figs. 6 -7).
4. Use a metal-cutting saw or chain tool, carefully cut both pipes at mark. Clean and de-burr edges of the catalytic converter newly cut pipe (Fig. 8).
5. Place a clamp on inlets of the **Assembly**. Insert and orient newly cut pipe sections into **Assembly**. Lightly tighten clamp nuts (Fig. 9).

Warning: Use extreme caution during installation. Torque all fasteners according to manufacturer's torque values and tightening sequence. DO NOT use air impact tools to tighten fasteners on Borla Performance Exhaust Systems. Use of such tools may result in bent flanges or gasket contact areas leading to exhaust leaks.

Note: When you first start your vehicle after the installation of your new Borla Performance Exhaust System, there may be some smoke and fumes coming from the system. This is a protective oil based coating used in the manufacturing of mandrel bent performance exhaust tubing. This is not a problem and will disappear within a very short period of time after the exhaust has reached normal operating temperatures.

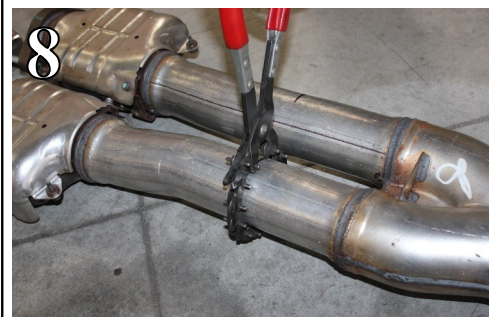

Caution!!! *Never work on a hot exhaust system. Serious injury in the form of burns can result if the vehicle has been in use and the exhaust system is hot, allow vehicle to cool for at least 1 hour. Always wear eye protection when working under any vehicle.*

Note: It is our recommendation that you use a hoist or hydraulic lift to facilitate the installation of your new Borla Performance Exhaust System.

Taking all under car safety precautions, lift the vehicle using a hoist or hydraulic lift. Once this has been done, you may begin the removal of your old exhaust system from your vehicle.

Note: Before removing the original exhaust system from your vehicle, please compare the parts you have received with the bill of materials provided on the previous page to assure that you have all the parts necessary for the installation of your new Borla Performance Exhaust System.

Note: With a used vehicle, we suggest a penetrating spray lubricant to be applied liberally to all exhaust fasteners and allowing a significant period of time for the chemical to lubricate the threads before attempting to disassemble.

Borla Performance Installation (continued)

6. Reinstall the **Assembly** inserting the outlets first then aligning the front-flanges to the factory cat-pipe (Fig. 10).
7. Use factory hardware to connect the front-flanges and rear hangars to vehicle. Begin tightening bolts at rear hangar making sure the mid-pipe is level. Tighten front-flanges hardware to factory specs making sure the flanges remain parallel (Fig. 11).
8. Before tightening over axle clamps, push both over axle pipes forward to verify tube seating into mid-pipe. Position clamp bolt between over pipe-notches and lightly tighten clamp nut with 15mm socket to 35 ft lbs. Repeat for other side (Fig. 12).
9. Use provided (4) bolts and carefully thread in to **Assembly** flanges. Tighten hardware to 35 ft lbs.
10. For **60558**, rotate front clamp bolts between pipe notches and tighten 15mm nuts to 35 ft lbs.

Warning: *Use extreme caution during installation. Torque all fasteners according to manufacturer's torque values and tightening sequence. DO NOT use air impact tools to tighten fasteners on Borla Performance Exhaust Systems. Use of such tools may result in bent flanges or gasket contact areas leading to exhaust leaks.*

Note: When you first start your vehicle after the installation of your new Borla Performance Exhaust System, there may be some smoke and fumes coming from the system. This is a protective oil based coating used in the manufacturing of mandrel bent performance exhaust tubing. This is not a problem and will disappear within a very short period of time after the exhaust has reached normal operating temperatures.

