

**PVG Owners/Service Manual  
Production Standards**

**Cover Stock: 22-24# Matte Cover**

**Text Stock: 22-24# Matte Book**

**Cover Ink: Black**

**Text Ink: Black**

**Size: 8.5"x11" (Portrait)**

**Bindery: Staple, upper left corner**

**Note: Manuals are to be printed Black &  
White and double sided.**

**Do Not Print**



**DIRECT-REPLACEMENT  
INSTALLATION GUIDE**

**CHEVROLET SILVERADO 1500 TRUCK 4WD / 2WD | 2019-ON  
GMC SIERRA 1500 TRUCK 4WD / 2WD | 2019-ON**

---

# **BILLET UPPER CONTROL ARM KIT**

---

803-35-008 - Kit: Control Arm, 2019-ON GM 1500 Upper Control Arm, Black  
803-35-009 - Kit: Control Arm, 2019-ON GM 1500 Upper Control Arm, Orange



FOX products are subject to continuous development and improvement. To find the most up to date product information such as color installation manuals, videos, and FAQs please visit:

<http://ridefox.com/manuals>

To locate the correct installation manual, use the 8-digit part number found on the end of the packaging box (see illustration below):



# CONTENTS

---

<b>INTRODUCTION</b>	<b>1</b>
<b>UCA SUPPLIED PARTS</b>	<b>2</b>
<b>UCA DIAGRAM</b>	<b>3</b>
<b>SAFETY INSTRUCTIONS</b>	<b>4</b>
<b>INSTALLATION GUIDELINES</b>	<b>5</b>
<b>UCA INSTALLATION</b>	<b>6</b>
<b>MAINTENANCE</b>	<b>13</b>
<b>WARRANTY INFORMATION</b>	<b>14</b>
<b>CONTACT INFORMATION</b>	<b>15</b>

# INTRODUCTION

---

Thank you for choosing FOX direct replacement, upper control arms for your vehicle. FOX products are designed, tested, and manufactured by the finest professionals in the industry.

FOX recommends that you become completely familiar with the handling characteristics of your modified vehicle before operating it under rigorous conditions, helping to avoid potential rollover situations and other loss of control events. FOX further recommends that you use appropriate protective equipment at all times when operating your vehicle.

To achieve the best performance and product longevity, periodic service and maintenance is required. Please refer to the Service and Upgrades section for more information.

## IN THE BOX

- Front Billet Upper Control Arms
- Supplied Hardware
- Installation Guide

# UCA SUPPLIED PARTS

FRONT UCA ASSEMBLY			
FOX PN	DESCRIPTION	QTY	NOTES
B1662	Bag Kit: Pivot Hardware	2	
	Misalignment: Pivot Misalignment	4	Hardware to mount the billet control arm to the frame
	Hardware: 3/4"-16 Jam Nut	2	
	Rod End: 3/4"-16 PTFE Lined Rod End	2	
	Hardware: 1/4"-20 x 1" Socket Head Cap Screw	4	
	Hardware: 3/8" Wire Loop Clamp	1	Hardware to attach ABS wires to the billet upper control arm
	Hardware: 1/4"-20 x 1/2" Button Head Hex Drive Screw	1	
B1663	Bag Kit: Taper Hardware	2	
	Hardware: 1/2"-20 Nylock Nut	1	Hardware to mount the billet control arm to the steering knuckle
	Misalignment: 1/2" Sunk Misalignment	1	
	Misalignment: Taper Misalignment	1	
	Hardware: 1/2"-20 x 4" Bolt, 12 Point	1	
	Hardware: 1/2" Stepped Washer	1	
	UCA Cap: Spherical Bearing Cap	1	Black: 803-35-008 Orange: 803-35-009
	Hardware: O-Ring Cap Seal	1	O-Ring seal for the cap to billet control arm
A5129-BLK	UCA: 2019-ON GM 1500 Billet Driver Side Upper Control Arm Assembly	1	Black: 803-35-008
A5130-BLK	UCA: 2019-ON GM 1500 Billet Passenger Side Upper Control Arm Assembly	1	
A5129-ORG	UCA: 2019-ON GM 1500 Billet Driver Side Upper Control Arm Assembly	1	Orange: 803-35-009
A5130-ORG	UCA: 2019-ON GM 1500 Billet Passenger Side Upper Control Arm Assembly	1	

# UCA DIAGRAM

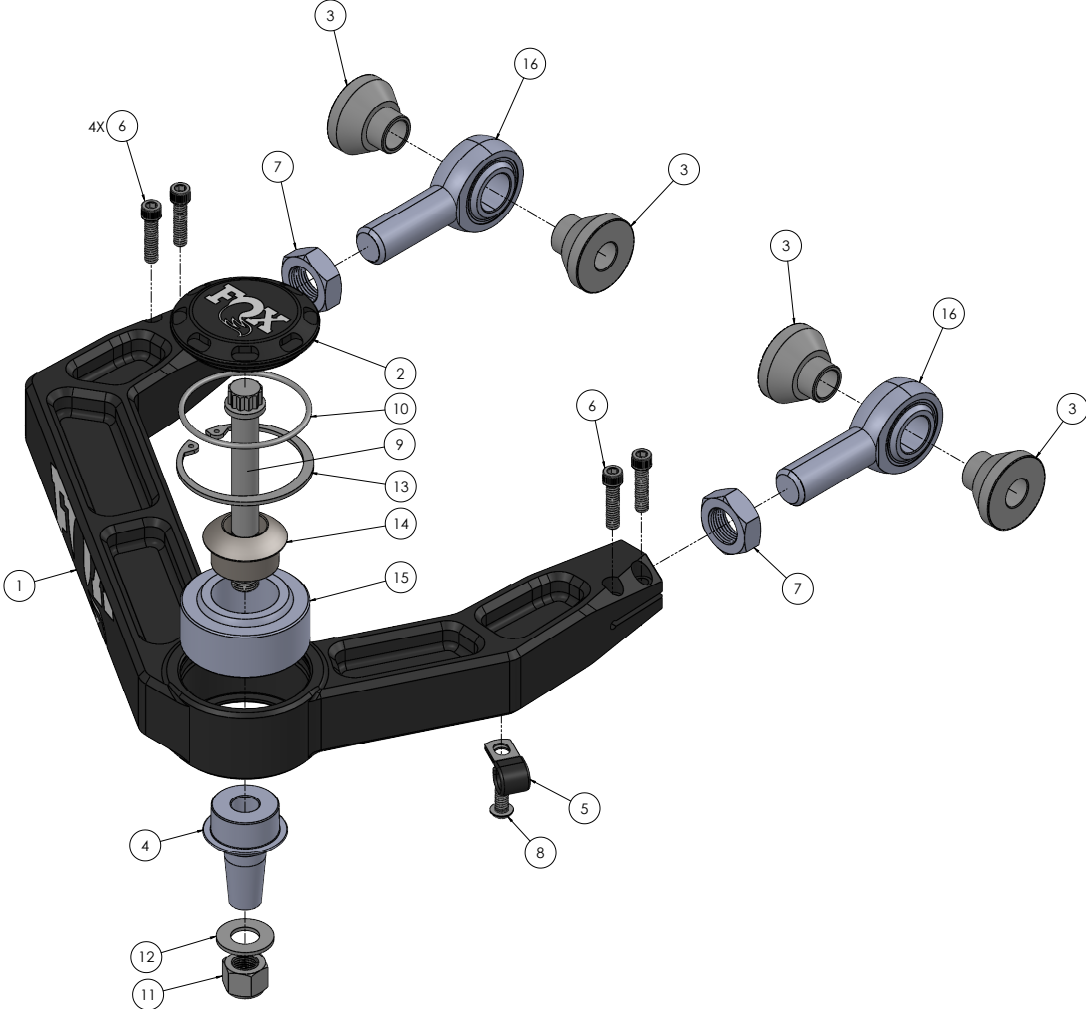

PART NO.	NAME	PART NO.	NAME
1	Billet Upper Control Arm	9	Uniball Bolt
2	Cap	10	O-Ring
3	Pivot Misalignment	11	Nut
4	Taper Misalignment	12	Washer
5	Wire Clamp	13	Snap Ring
6	Pinch Bolts	14	Sunk Misalignment
7	Jam Nut	15	1.25" Spherical Bearing
8	Wire Clamp Bolt	16	3/4" Rod End

 **WARNING**

# SAFETY INSTRUCTIONS

---

- FOX direct-replacement UCA's are designed to fit and allow proper clearance with the stock suspension. If aftermarket suspension components are installed it is the customer's responsibility to ensure that interference between the FOX UCA's and other vehicle components does not occur at any point in the shock stroke.
- FOX direct-replacement UCA's should always be installed as a set for maximum performance.
- Proper installation and service procedures are essential for the safe and reliable operation of the suspension components, requiring the experience and tools specially designed for this purpose. Installation and maintenance procedures for this product must be performed by a qualified service technician, to avoid potentially unsafe vehicle handling characteristics, which may result in **SERIOUS INJURY** or **DEATH**.
- Modifying your vehicle's suspension will change the handling characteristics of your vehicle. Under certain conditions, your modified vehicle may be more susceptible to loss of control or rollover, which can result in **SERIOUS INJURY** or **DEATH**. Thoroughly familiarize yourself with the modified vehicle handling characteristics before any rigorous vehicle operation. Wear protective body gear and a helmet when appropriate. Installation of vehicle roll bars or cage is highly recommended.
- Any attempt to misuse, misapply, modify, or tamper with any FOX product voids any warranty and may result in **SERIOUS INJURY** or **DEATH**.

**⚠ WARNING**

# INSTALLATION GUIDELINES

- Always use a chassis lift for the installation of any aftermarket parts, and make certain that the raised vehicle is securely attached to the lift to prevent the vehicle from slipping, falling, or moving during the installation process.
- DO NOT install any FOX product without the necessary special tools, expertise and chassis lift or you will subject yourself to the risk of SERIOUS INJURY or DEATH. If you elect to not use a chassis lift (which may result in SERIOUS INJURY or DEATH), ensure that the vehicle is: (1) on level ground, (2) that all tires on the ground during installation are blocked to prevent vehicle movement, (3) that at least two tires are on the ground at all times, and (4) that adequately secured jack stands are used to support the vehicle. NEVER get under the vehicle until you have checked to ensure that the vehicle will be stable during installation.
- Do NOT hit the aluminum knuckle on later model trucks with a hammer to separate the ball joint. Use appropriate ball joint separation tool.
- These control arms will NOT work with a GMC Denali or some Chevy High Country trucks with the Adaptive Ride Control (ARC) suspension.
- Service Kit Information:

Part Type	Part Number
Single Spherical Rod End Bearing	001-01-003
Single Spherical Uniball Bearing	001-00-015
Pair Spherical Uniball Bearing Cap - Black	006-00-065
Pair Spherical Uniball Bearing Cap - Orange	006-00-066
UCA Complete Rebuild Kit (X2 Control Arms)	803-04-368

- Wheel / Tire Fitment Information:

Wheel Specification	Tire Specification	Fitment Notes
17" and 18" Stock Wheel	Stock Tires	Wider than stock tires on any stock wheels will rub on the Billet Fox UCA. 20" and 22" OE tires and wheels will rub the Billet Fox UCA during full suspension travel. Stock 17" and 18" wheels with stock tires will work with the Billet FOX UCA.
17" x 8.5" 4.5-5" Back Spacing	Up to 12.50" Wide Tire	Tire diameter is relative to lift height
17" x 8.5" 5.5" Back Spacing	Up to 295 Width Tire	
18" x 9" 4.5-5" Back Spacing	Up to 12.50" Wide Tire	
18" x 9" 5.5" Back Spacing	Up to 295 Width Tire	
20" x 9" 4.5-5" Back Spacing	Up to 12.50" Wide Tire	
20" x 9" 5.5" Back Spacing	Up to 295 Width Tire	

# UCA INSTALLATION

---

## PREPARATION

1. Please read the installation guidelines on page 5 for instructions on how to properly lift and secure the vehicle.

**NOTICE:** Medium-strength thread-lock is recommended on all bolts.

## TOOLS REQUIRED

- Basic Hand Tools / Socket & Wrench Set
- Jack Stands
- Tape Measure
- Cut Off Wheel / Reciprocating Saw
- Ball Joint Separator Tool
- Medium-Strength Thread Locker
- Torque Wrench

## DISASSEMBLY

1. Park the vehicle on a clean, flat surface and block the rear wheels for safety.
2. Raise the front of the vehicle and support the frame rails with jack stands.
3. Remove the front wheels.
4. Disconnect the front driver's and passenger's side sway bar links from the lower control arm (Fig. 1). Save hardware.

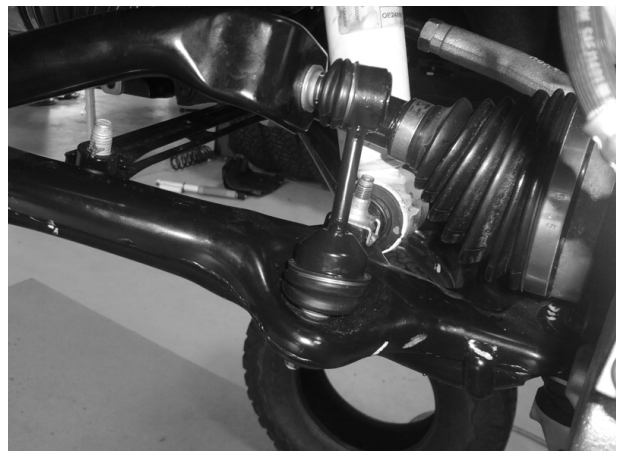

Fig. 1: Disconnect sway bar link.

5. Perform the following installation steps on one side at a time. Remove the wire retaining clips from the stock coil-over studs and loosen but do not remove the three upper mount nuts at the frame (Fig. 2). Do not loosen- the center nut. For the passenger side inner nut it may be easier to access the nut through the engine bay.
6. Remove the nut from the steering tie rod end (Fig. 3). Dislodge the tie rod end taper from the knuckle. Remove the nut and the tie rod end from the knuckle.
7. Unclip the ABS wire from the knuckle for additional slack (Fig. 4).



Fig. 2: Loosen the 3 upper mount nuts.

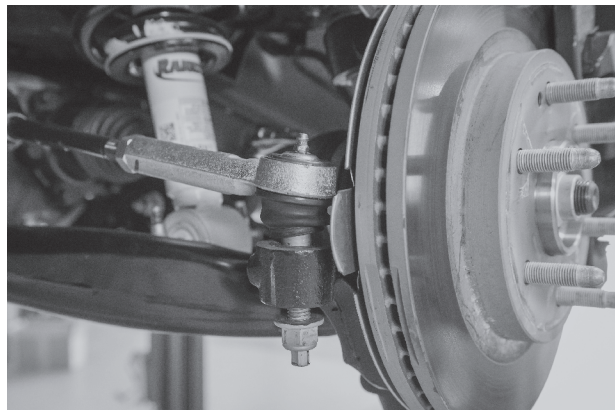

Fig. 3: Remove tie rod end nut.



Fig. 4: Unclip ABS wire.

8. Support the lower control arm with a hydraulic jack and remove the nut from the upper ball joint (Fig. 5A). Dislodge the rod end taper from the knuckle. Allow the knuckle to swing rearward out of the way (Fig. 5B). A strap can be used to hold the knuckle back in order to prevent the CV axle from pulling out of the inner joint.
9. Remove the two lower stock coil-over bar pin bolts (Fig. 6). Lower the control arm so there is enough room to remove the factory strut.

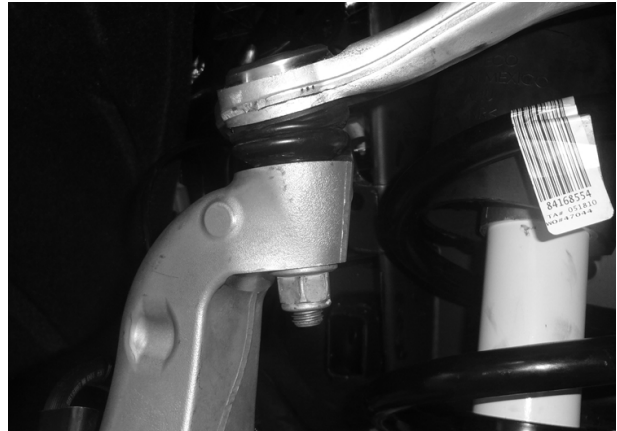

Fig. 5A: Remove nut and disconnect.

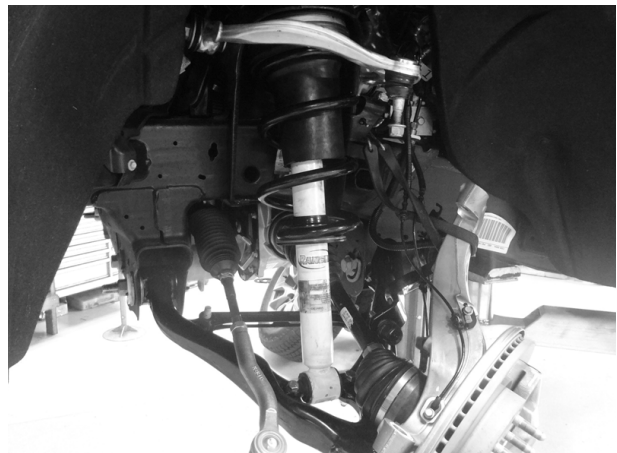

Fig. 5B: Use strap to hold knuckle.



Fig. 6: Remove 2 bar pin bolts.

10. Remove the three nuts attaching the stock coil-over to the frame (Fig. 7). Remove the stock coil-over from the vehicle. DO NOT remove the center strut rod nut.
11. Remove the ABS wire / brake sensor wire from the upper control arm. Remove the upper control arm from the vehicle by removing the two bolts attaching the upper control arm to the coil-over bucket / frame (Fig. 8).
12. The tab on the side of the strut bucket must be removed to avoid interfering with new control arm assembly. Cut the tab from the side of the strut bucket as shown in (Fig. 9).



Fig. 7: Remove the three nuts, NO NOT REMOVE CENTER NUT.



Fig. 8: Remove ABS wire then remove UCA.

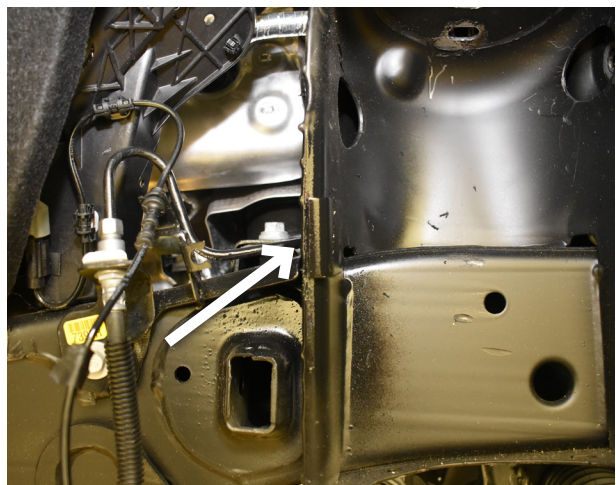

Fig. 9: Cut tab from strut bucket.

## UPPER CONTROL ARM ASSEMBLY

13. Install the 3/4" jam nuts onto the pivot heims all the way till the jam nut bottoms out (Fig. 10).
14. Lightly anti-sieze the 3/4" female threads of the control arm. Install the heim joints with the jam nuts into the female threads of the control arm (Fig. 11).
15. Thread the heim joint into the control arm until there is approximately 5/8" between the control arm surface and base of the heim joint. Line up the heim joints such that they are "vertical" relative to the control arm. Snug up the jam nut at this time (Fig. 12).



Fig. 10: Install the 3/4" jam nuts.



Fig. 11: Install heims into UCA.

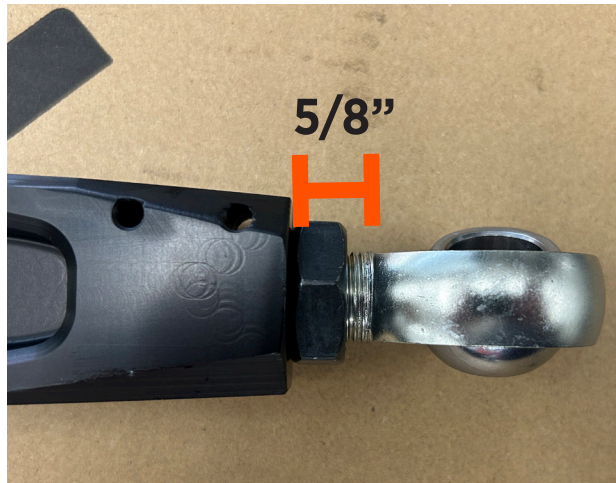

Fig. 12: Set to 5/8".

- Using blue thread locker, install the (4) 1/4"-20 bolts into the pinch joints onto the control arm and torque to 107 in-lbs at this time. After the 1/4" pinch bolts are torqued, tighten the jam nuts to 90 ft-lbs (Fig. 13).

#### FRONT ASSEMBLY

- If installing with FOX Coil-overs, install the coil-overs at this time. Follow instructions included with the coilovers or reference the coil-over install instructions on FOX's website.
- Install the pivot misalignments into the heims on the upper control arm (Fig. 14).
- Install the new upper control arm to the vehicle using the OE hardware and blue thread locker. Run the bolts from the inside out of the strut bucket outwards with the nut on the outer misalignment surface. Do this for the front and rear control arm mounts (Fig. 15). Torque the control arm hardware pivot to OE torque specifications. Passenger side shown in the figure. Dislodge ball joint by striking knuckle with hammer, or using a pickle fork which is recommended for aluminum knuckles.
- Insert the sunk misalignment and 12 pt. bolt through the top of the uniball joint. Install the longer bottom taper misalignment to the other end of the bolt with the taper side down to fit into the steering knuckle (Fig. 16).



Fig. 13: Loctite and install pinch bolts.



Fig. 14: Install misalignments.



Fig. 15: Remove UCA Bolt.



Fig. 16: Assemble uniball joint.

21. Angle the joint misalignments in order to help attach the upper control arm to the steering knuckle. Initial movement of the uniball joint will be stiff until the joint is installed on the vehicle. Inserting the bolt into the misalignment and moving it may help to break free the uniball joint from its installed position (Fig. 17).
22. If installing with FOX Coil-overs, install the coil-overs at this time. Follow instructions included with the coilovers or reference the coil-over install instructions on FOX's website.
23. Attach the taper misalignment joint to the upper control arm taper on the steering knuckle. Use the provided 1/2" 12 point bolt through the misalignments and attach to the steering knuckle using the washer and nylock nut. Torque the upper uniball nut to 80 ft-lbs Fig. 18).
24. Reattach the tie rod to the knuckle and torque to OE specifications.
25. Repeat installation on the opposite side of the vehicle. When both sides are complete, reattach the sway bar links and tighten hardware to OE specifications.
26. Attach the brake line and ABS wires to the factory position on the knuckle. Use the provided wire clamps and 1/4" bolt with blue thread locker to attach the brake wire / ABS wire to the bottom side of the upper control arm. Torque the 1/4" hardware to 76 in-lbs. Check for enough slack in the wires and adjust as necessary (Fig. 19).
27. Install the O-ring onto the cap and lightly grease the O-ring to help seal the cap to the control arm. Line up the groove on the cap towards the inside of the vehicle, such that the FOX logo is facing outwards towards the tire.
28. Reinstall the front wheels and lower the vehicle to the ground. Torque lug nuts to OE specifications.

#### POST INSTALLATION INSTRUCTIONS

29. Check all hardware for proper torque.
30. Check hardware after 500 miles.
31. Adjust headlights.
32. The vehicle will need a complete front end alignment.
33. Cycle the steering to check for adequate ABS slack, adjust as necessary.



Fig. 17: Insert bolt.



Fig. 18: UCA Bolt.

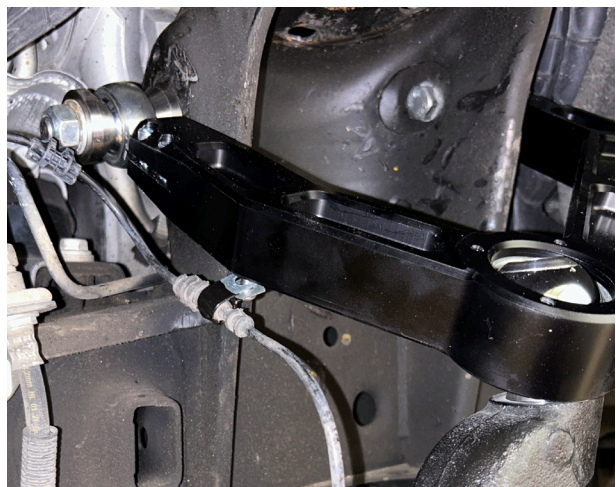

Fig. 19: Install ABS wire mount.

# MAINTENANCE

---

PROPER INSPECTION AND MAINTENANCE IS ESSENTIAL TO MAINTAIN THE PERFORMANCE AND RELIABILITY OF YOUR BILLET UPPER CONTROL ARMS.

To avoid corrosion, you should keep the billet upper control arms, free of dirt and moisture. The spherical bearing and rod ends are lined with a PTFE lubricant for long life when kept clean. Make sure you clean these areas completely to prevent corrosion on the joints. Avoid using a high-pressure washer near the O-ring cap seals, as this could drive dirt and moisture inside the cap.

Make sure the O-ring seal is lubricated with grease to prevent moisture from entering the sealed cavity and causing corrosion on the spherical bearing.

Clean the pockets of the control arm to prevent dirt from scratching the anodized coating to ensure a long life of the coating.

## FOX SERVICE AND UPGRADES

CALL OUR CUSTOMER SERVICE CENTER AT 800.269.7469 EXT. 2 OR EMAIL US AT [ORSALES@RIDEFOX.COM](mailto:ORSALES@RIDEFOX.COM) TO GO OVER THE SERVICE OPTIONS AVAILABLE FOR YOUR BILLET UPPER CONTROL ARM.

## COMPLETE SERVICES

ALL OF OUR SPHERICAL BEARINGS COME WITH A LUBRICANT INFUSED LINER, IT IS NOT RECOMMENDED TO FURTHER LUBRICATE THESE SPHERICAL BEARINGS AS THIS COULD CAUSE PREMATURE FAILURE

INSPECT FOR PLAY IN THE SPHERICAL BEARINGS AND SPHERICAL ROD END AFTER ANY OFF-ROAD USE

CLEAN OFF DIRT FREQUENTLY FOR LONGEST LIFE

INSPECT JAM NUTS AT LEAST ONCE EVERY THREE MONTHS



**WARNING: Cancer and  
Reproductive Harm –**  
[www.P65Warnings.ca.gov](http://www.P65Warnings.ca.gov)

# WARRANTY INFORMATION

---

## **BILLET UPPER CONTROL ARMS**

- Additionally, Fox Factory, Inc. offers a lifetime warranty except for (i) all serviceable components of the Upper Control Arms including spherical bearings, rod ends, other fabricated hardware and (ii) appearances and finishes based on issues with workmanship. Serviceable components and appearances/finishes are limited to a twelve (12) month warranty. Damage by use and abuse is not covered.
- Please note that certain sounds, including those resembling a “race car” noises such as squeaks or creaks, may be normal for specific models or configurations. These sounds are often associated with the design and operation of the vehicle and do not necessarily indicate a mechanical issue. However, if you hear noises such as clunks or thuds please bring your vehicle to a qualified mechanic for review.
- This warranty covers any repair or replacement necessary for defects in materials or workmanship, excluding sounds that result from standard operation of the vehicle’s performance features

# CONTACT

---

## **FOX RACING SHOX**

A DIVISION OF FOX FACTORY INC.

## **SALES**

750 Vernon Way, Suite 101

El Cajon, CA 92020

1.800.FOX.SHOX (1.800.369.7469)

[orsales@ridefox.com](mailto:orsales@ridefox.com)

